



Liquid Vapor Controller LVC 414

Features

- True vapor mass flow in bubbler systems.
- Defeats influence of liquid level, temperature and pressure.
- Liquid level surveillance possible.
- Mounting position insensitive.
- Good surface finish for ultra clean operation.
- Various gas fitting configurations.
- Heating temperature of bubbler much lower compared with direct vaporization.
- Thermal control valve design gives :
 - reliability,
 - a normally open flow path for gas line purging when power is off



Ratings

Carrier gas flow range : from 50 sccm to 10 slm.
 Vapor flow range :from 12 mgram/min to 40 gram/min.
 Minimum carrier gas flow : 5% F.S.
 Maximum source flow: 40 gram/min.

Accuracy : +/- 4% of F.S.
 Linearity : +/- 4% of F.S.
 Repeatability : +/- 0.5% of F.S.
 Sensibility to Mounting Position : +/- 0.1% of F.S.
 Carrier Gas Response Time : 10 sec. Typical.

Gas & ambient temperature range :between 15 and 35°C.
 up to 43°C on request.
 Carrier gas Temperature Coefficient < 0.1% F.S./°C.
 Operating pressure range differential : between 60 kPa 300 kPa (0.6 bar & 3 bar, 8.7 psi & 43 psi).
 Maximum line pressure : 400 kPa (4 bar, 58 psi).
 Carrier gases : H2, He, N2, O2, Ar, mixed gas.

Wetted Materials : 316 L Stainless.
 Leak Integrity : < 2.10⁻⁸ atm.scc/sec (He).
 Standard Seals : Viton, option Kalrez.
 T.C. Filaments : Gold plated tungsten or nickel.
 Gas connection : on request.

Power Input Requirement :

Power voltage : +/- 15 VDC.
 Power consumption : 15 watt max.
 Command setting (setpoint) : 0.5 - 5 VDC.
 Output Signal :
 Source : 0.5 - 5 VDC.
 Carrier : 0.25 - 5 VDC.
 Ratio : 1 - 5 VDC.

These signals are linearly proportional to the mass flow rate of vaporized liquid, to the mass flow rate of carrier gas and to ratio vapor flow to carrier flow respectively

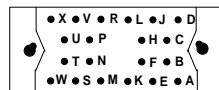
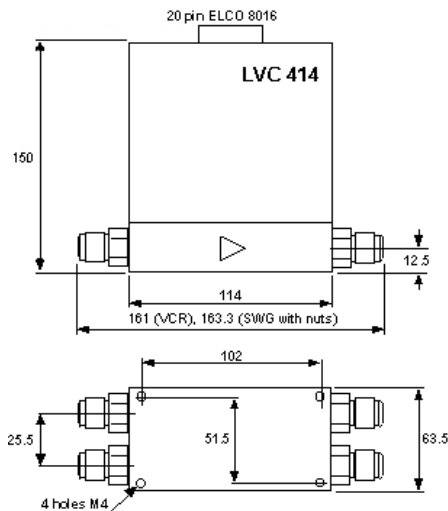

E	GND	N	Source Readout
F	Setpoint (0-5 V)	P	Signal Com
H	Signal Com	S	Power Com
J	Valve control	T	-8 VDC output
K	Ratio Readout	V	Test point
L	+5 VDC output	W	-15 VDC
M	Carrier Readout	X	+15 VDC

LVC SYNOPSIS

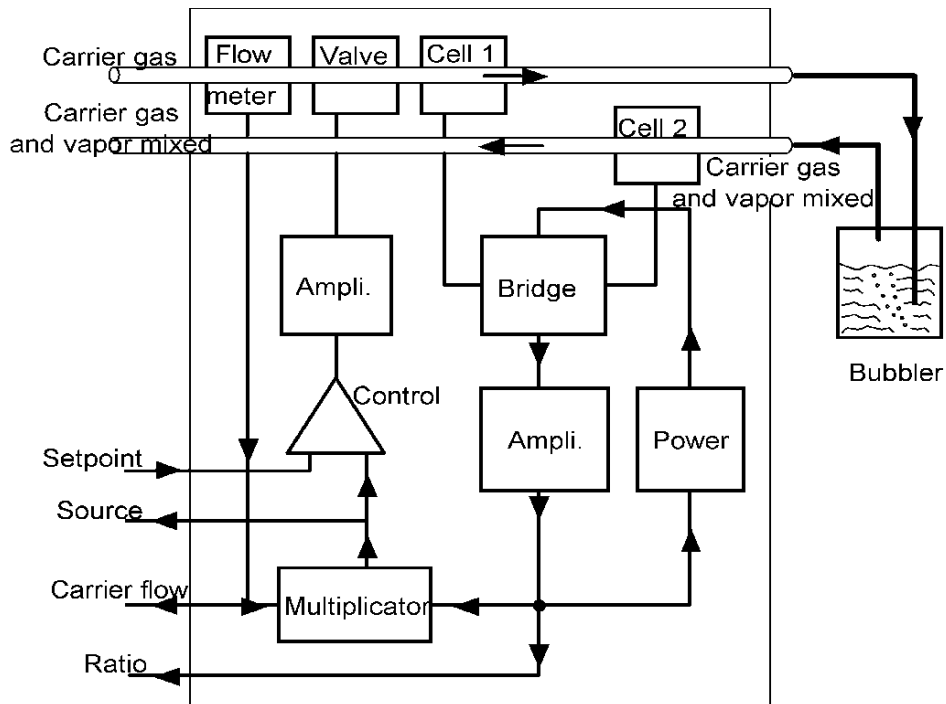

SELECTION CHART

Full Scale (sccm)	Full scale source Flow (grams per minute) when LVC 414 is calibrated at 21°C for :							Full scale source Flow (grams per minute) when LVC 414 is calibrated at 35°C for :				
	SiHCl ₃	SiCl ₄	GeCl ₄	BBr ₃	POCl ₃	CCl ₄	SiCl ₂ (CH ₃) ₂	SiCl ₄	GeCl ₄	BBr ₃	POCl ₃	SiCH ₃ Cl ₃ (MTCs)
50	0.250	0.100	0.040	0.033	0.0125	0.040	0.0375	0.250	-	0.075	0.025	0.0375
75	0.375	0.150	0.060	0.050	-	0.060	-	0.375	0.100	-	-	-
100	0.500	0.200	0.080	-	0.025	0.080	0.075	0.500	-	0.150	0.050	0.075
150	0.750	0.300	0.120	0.100	-	0.120	-	0.750	0.200	-	0.075	-
200	1.00	0.400	0.160	-	0.050	0.160	0.150	1.00	-	0.300	0.100	0.150
250	1.25	0.500	0.200	-	-	0.200	-	1.25	-	-	0.125	-
300	1.50	0.600	0.240	0.200	0.075	0.240	0.225	1.50	0.400	0.450	0.150	0.225
500	2.50	1.00	0.400	-	0.125	0.400	0.375	2.50	-	0.750	0.250	0.375
750	3.75	1.50	0.600	0.500	-	0.600	-	3.75	1.00	-	0.375	-
1000	5.00	2.00	0.800	-	0.250	0.800	0.750	5.00	-	1.50	0.500	0.750
2000	10.00	4.00	1.60	-	0.500	1.60	1.500	10.0	-	3.00	1.00	1.500
3000	15.00	6.00	-	2.00	-	2.40	-	15.0	4.00	-	-	-
5000	25.00	10.00	-	-	-	4.00	-	25.0	-	-	-	-
7500 (H ₂ only)	37.50	15.00	-	-	-	-	-	37.5	-	-	-	-
10000 (H ₂ only)	-	20.00	-	-	-	-	-	-	-	-	-	-
Full Scale Ratio (%)	200	50	12	10	5	15	25	100	20	20	10	50



Liquid Vapor Controller Part Number Description

S [f] [s] [v, v, v, v] [l] [c, c, c, c] [g] [r, r, r] [c] - [o]

[f]- Fittings

- [M] for 1/4" VCR Male
- [C] for Swagelok 1/4"

[s]- Seals

- [V] for Viton
- [K] for Kalrez (mixing side only)

[v, v, v, v] Vapor flow range

Specify range in mgr/min.

Example :

- [37G5] for 37,5 g/mn
- [250M] for 250 mg/mn
- [25G0] for 25 g/mn
- [05G0] for 5 g/mn

[l]- Liquid source

- [A] for SiHCl₃
- [B] for SiCl₄
- [C] for GeCl₄
- [D] for BBr₃
- [E] for POCl₃
- [F] for CCl₄
- [G] for SiCl₂(CH₃)₂
- [H] for t-DCE
- [I] for SiCH₃Cl₃

[c, c, c, c]- Gas Carrier Flow

Specify C for sccm, L for slm.

Example :

- 200C for 200 sccm
- 001L for 1 slm
- 01L5 for 1.5 slm

[g]- Gas Carrier

- [A] for He (only for SiCl₄)
- [B] for Ar (only for SiCl₄)
- [C] for H₂ (only for SiCl₄ & SiCH₃Cl₃)
- [D] for N₂ (only for SiCl₄)
- [E] for O₂
- [F] for 50%H₂ in Ar (MTCS)

[r, r, r]- Ratio

Specify ratio in %.

Example :

- [010] for 10%
- [200] for 200 %

[c]- Cell

Internal use parameter.

- [G] for Gold/Tungsten
- [N] for Nickel
- [D] for Double Nickel

[o]- Option

- [L] for Modification Low
- [H] for High Temperature

