



MFC Principles
A basic course



QUALIFLOW Montpellier (headquarters)

350, rue A. Nobel
BP7- 34935 MONTPELLIER
CEDEX 9
France
tel: +33 4 67 99 47 47
fax: +33 4 67 99 47 48

QUALIFLOW Inc,

24 Goose Lane
Tolland
CT 06084
USA
tel: +1 860 871 0401
Fax: +1 860 871 9233

QUALIFLOW Technology Center

44862 Osgood Road
Fremont
CA-94539
USA
tel: +1 510 440 93 74
fax: +1 510 440 93 75

QUALIFLOW NRT Korea

10 Block-17 Lot, Namdong Ind.
CLX. #623-16n Namchon-Dong, Namdong-Ku
KOREA
tel: +82 (0)2 3401 6491
fax: +82 (0)2 3401 6493

Identification					
Reference	n.a.	Revision	1.2	Date	06 Sept 2001
Document name		MFC Principles			
File name		MFC Principles.doc			

History				
Author	Date	Description	Revision	Status
Pierre Navratil	21/06/2000	Initial version	1.0	Completed
Pierre Navratil	25/01/01	Bypass description Modified	1.1	Completed
Pierre Navratil	06/09/01	Revision of the document	1.2	Completed

Summary

MFC PRINCIPLES	5
MEASUREMENT PRINCIPLES	5
SENSORS PRINCIPLES	6
BYPASS PRINCIPLES	8
CONTROL PRINCIPLES	9

MFC PRINCIPLES

Mass Flow Controllers (MFCs) are used wherever accurate measurement and control of a mass flow of gas is required independent of flow pressure change and temperature change in a given range.

Mass Flow Meters (MFMs) are used wherever accurate measurement of gas is required without control of the flow, which is done by another device.

To help understand how an MFC works, it can be separated into 4 main components: a bypass, a sensor, an electronics board and a regulating valve:

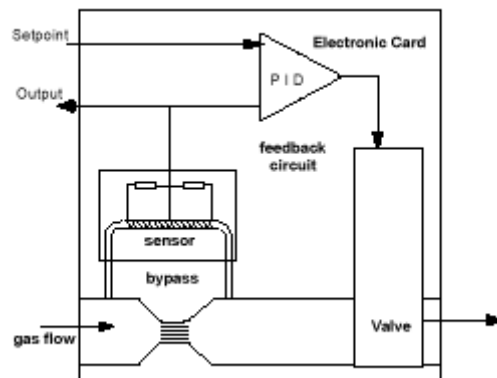

FIG. 1. Schematic of the mass flow controller.

The bypass, the sensor, and one part of the electronics board are the measurement side of the mass-flow controller and make a Mass Flow Meter.

The regulating valve and the other part of the electronics board are the controlling side of the mass-flow controller and exist only on a Mass-Flow Controller.

So every Mass-Flow Controller includes a Mass-Flow Meter.

MEASUREMENT PRINCIPLES

The flow is divided between a heated sensing tube (the sensor), where the mass flow is actually measured, and a flow restrictor or bypass, where the majority of flow passes.

The bypass is designed in a way that flow thru the sensor and the bypass is always proportional to the flow range for which the mass-flow controller is built.

The sensor is designed to deliver an output voltage almost proportional to the gas flow circulating thru it, which is due to the bypass design being proportional to the total flow circulating thru the mass-flow meter or controller.

The electronics board amplifies and linearizes the sensor signal so the output of the electronics board, named "readout", gives a signal proportional to the total flow circulating thru the mass-flow meter or controller. Most of the time this signal is a 0-5 V signal; 0 volts indicating "no flow", 5 volts indicating full scale flow of the device. Full scale is the maximum flow for which the mass-flow controller is designed and calibrated to work with at high accuracy. This information is always written on stickers, which are on the top of the cover

and the side of the mass-flow stainless steel base. Also written on the sticker is the gas for which the mass-flow controller is calibrated.

Why use a bypass? Because the sensor element can only measure small flow (typically 5 sccm), the bypass/restrictor allows the controller to control and measure greater amounts of flow. On a 5 sccm full scale mass-flow controller, there is no bypass, all of the gas would flow thru the sensor. On a 100 sccm full scale mass-flow controller, the bypass is adjusted so that when 100 sccm flows thru the controller, 5 sccm will flow thru the sensor tube and 95 sccm will flow thru the bypass.

SENSORS PRINCIPLES

Basically, the sensor uses the thermal properties of a gas to directly measure the mass flow rate. The sensor uses the basic principle that each gas molecule has a specific ability to pick up heat. This property, called the "specific heat" (C_p), directly relates to the mass and physical structure of the molecule and can be determined experimentally. The specific heat is well known for many gases and is generally insensitive to changes in temperature or pressure.

By adding heat to a gas and monitoring the change in temperature, the mass flow rate can be determined. To illustrate this concept, take the case of cool gas flowing through a heated tube. Mathematically, the heat loss can be described by the First Law of Thermodynamics,

$$q = F \cdot C_p \Delta T$$

Where

q is the heat lost to the gas flow,

F is the mass flow,

C_p is the specific heat for a constant pressure,

ΔT is the net change in gas temperature as it traverses the tube.

It is important to realize that both the specific heat and the flow rate determine the amplitude of the heat flux. As the mass and physical structure of molecules vary widely from gas to gas, so does the specific heat C_p . For the same molar flow rate, the heat flux can differ significantly for different gases. If this heat flux is monitored, the amplitude can be converted into an electrical signal. Given that the specific heat is known for the gas, the mass flow rate can then be determined directly from the electrical signal.

The MFC sensor includes a capillary tube wound with two heated resistance thermometers, measuring the change in temperature distribution created by the gas flowing inside this tube:

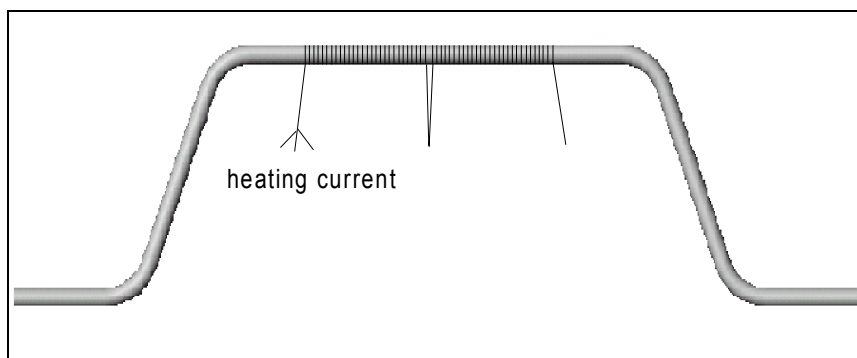

Sensor schematic

For zero flow, the upstream and downstream temperature will be equal. The windings are heated electrically to 80°C above ambient temperature. When the gas is flowing, the upstream region cools down whereas the downstream region heats up causing a temperature gradient along the length of the tube (see the sensor temperature profile figure).

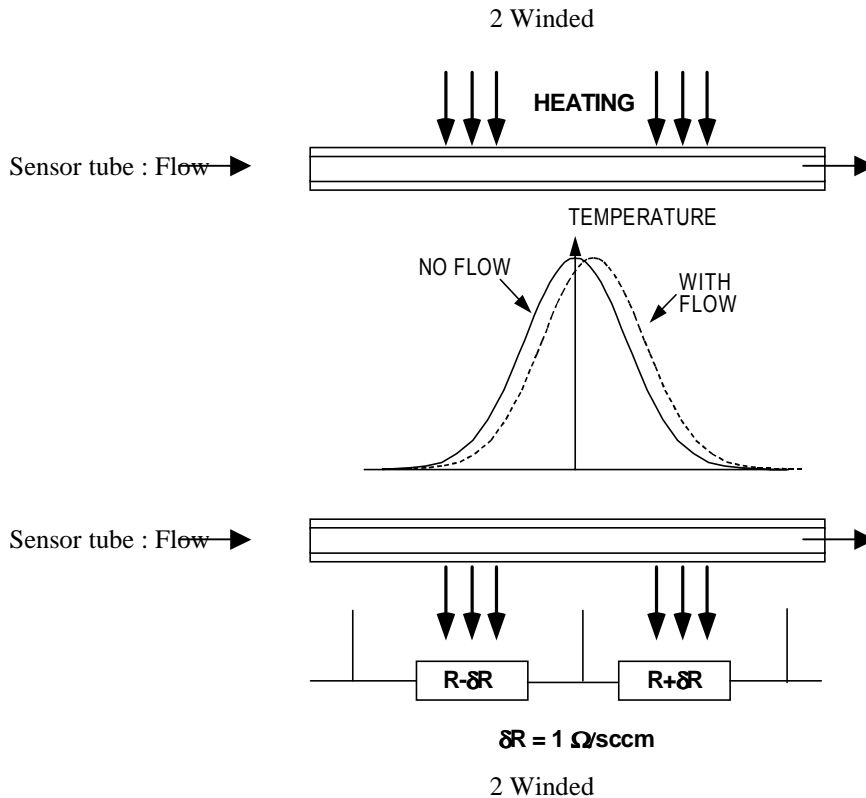

Sensor temperature profile

The coils of the heating resistances are made with a thermal sensitive wire so that the temperature differences due to the flow are directly converted into resistance changes. These resistance changes are converted to a voltage by a simple Wheatstone bridge.

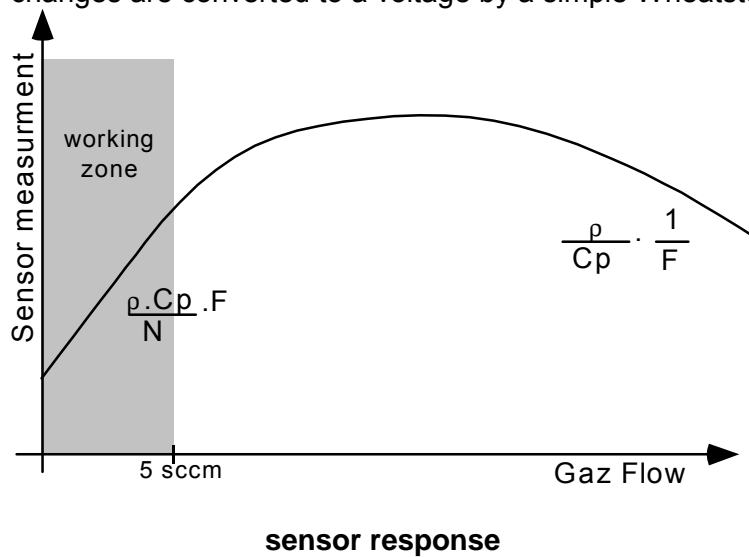

For flow under 5 sccm the measurement is proportional to the flow with a coefficient which depends on :

ρ : Volumic mass of the gas

C_p : specific heat for a constant pressure,

N : "spin factor" Constant which depends on the molecular structure of the gas and compensates for the temperature dependence of C_p .

Value of N :

Monoatomic gas 1.04

Diatomic gas 1.00

Triatomic gas .94

Polyatomic gas .88

For flows higher than 5 sccm, the sensor is at first non-linear. Then the measurement starts to decrease with flow because the gas flow is too fast and cools the 2 wound resistance wires instead of cooling the first one and heating the second one. This is the reason why a bypass is necessary for higher full scale than 5 sccm.

Also the fact that the coefficients N and C_p are different from one gas to another explains why mass-flow CANNOT be changed from one gas to another without using a special coefficient to convert the measurement or recalibrate the mass-flow.

Because of sensor saturation, if flow is ten times the full scale, output will be almost "no flow"! This will never happen on a mass-flow controller as the valve acts as a restrictor and will not allow the gas to flow at ten times the full scale. But it can easily happen on a mass-flow meter; if there is no restriction in the gas line there is nothing in the mass-flow meter to limit the gas flow.

BYPASS PRINCIPLES

Acting as a restrictive element, the bypass is composed of a series of capillary tubes (or bypass washers that also come in different slot sizes for different flow ranges) held in a special bypass ring. The ring fits around the body and may hold up to 24 tubes. The number of tubes and their diameter will depend on the customer's specifications of gas type and flow range. For higher flow rates, the bypass tubes are replaced by a screen.

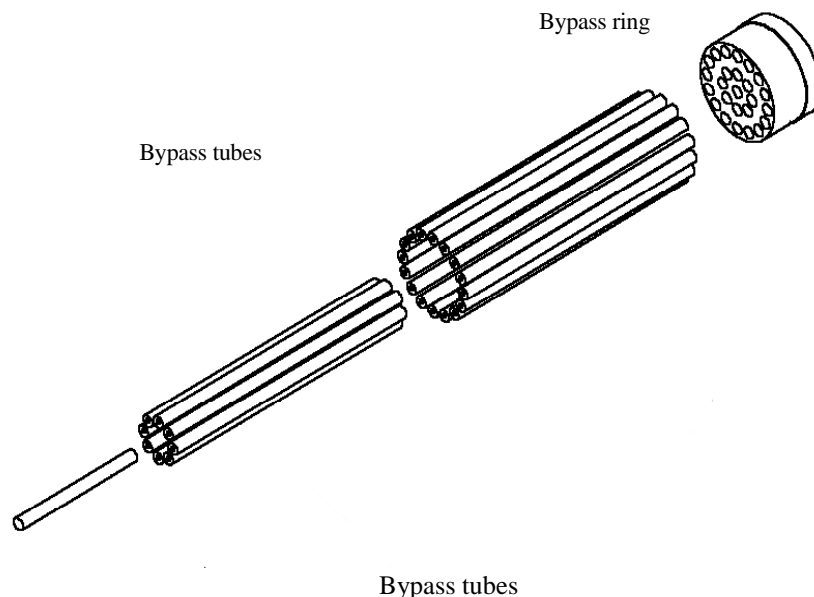

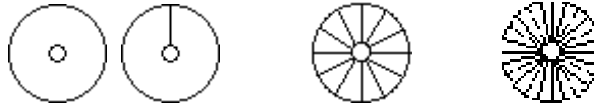

Bypass washers (equivalent to several thin tubes)

The bypass principles are based on the laminar flow theory: When flow is laminar, the flow is proportional to the differential pressure between the inlet and outlet of the tube:

$$F_m = \rho \cdot \frac{\pi \cdot R^4}{8 \cdot \eta \cdot l} (P_{up} - P_{down})$$

- ρ : Volumic mass of the gas
- η : Viscosity of the gas
- l : length of the tube
- R : radius of the tube

So when a sensor tube (radius R_s , length l_s) and a bypass tube are in parallel (radius R_b , length l_b), the flow in the sensor tube is proportional to the flow in the bypass:

$$F_s = \frac{R_s^4 \cdot l_s}{R_b^4 \cdot l_b} \cdot F_b$$

However, this is true only if the flow is laminar and if the tubes are small enough. This is why the bypass is made of several thin tubes instead of only one tube.

It is important to note that the flow measured thru the sensor of a mass-flow meter or controller is not the total flow, but only one part of the flow split by the bypass according to last equation. In this equation, the radius of the sensor tube and bypass tube is at power 4. Consequently, any deposition in one of the tubes, changing the diameter, will change the accuracy of the measurement. Because of the need to have laminar flow, mass-flow meters and controllers must be used with clean, filtered gases to avoid clogging in the bypass tubes and sensor tube.

CONTROL PRINCIPLES

The electronics board compares the amplified mass flow rate value (measured by the sensor) to the desired set point. This comparison generates an error signal that "feeds" the regulating valve. The difference is used to drive the control valve. The control valve will proportionally open or close until the output is equal to the setpoint.

Note that valve can be normally open or normally closed. This is the position that the valve will be in when the mass-flow controller is not connected to a power supply.

The valve can be actuated by a magnetic solenoid, which can be normally open or normally closed. The response time of the valve itself is almost instantaneous. In practise, however, the response time of the mass-flow controller is limited by the response time of the sensor. As a sensor is based on thermal exchange, it takes 1 to 5 sec. for the sensor to measure a gas change. Several techniques allow us to increase this response time and allow us to get the best mass-flow response time below 5 sec.

The valve can be also made by a heating wire which heats a small tube, then dilation will move a ball at the end of the tube. This thermal type of valve can be only normally open and is quite slow. Mass-flow controllers using this valve will have response times around 5 to 6

qualiflow

sec. for flow below 5 slm and up to 10 sec. for flow up to 5 slm!! However this technology is simple and reliable and is recommended for many low cost applications when response time is not critical.